

# ID FIRST TECHNICAL SHEET

CE standard.  
Domes patented in Japan and the United States.  
Catalyst patented by INPI.

## DIMENSIONS

**Length:** 225 cm  
**Width :** 90 cm  
**Height (table):** 50 cm  
**Upper dome:** 91 cm x 72 cm x 44 cm  
**Lower dome:** 91 cm x 61 cm x 39 cm

## COMPOSITION

**Outside Domes:** artificial leather  
**Domes interior:** 5 Black Carbon panels  
**Catalyst:** ceramic/titanium - technology  
**Mattress:** 50 mm foam - 30 kg/m<sup>3</sup>  
**Polyurethane cover:** cream  
**Cushion:** white artificial leather  
**Table:** Metal structure + wood panels covering

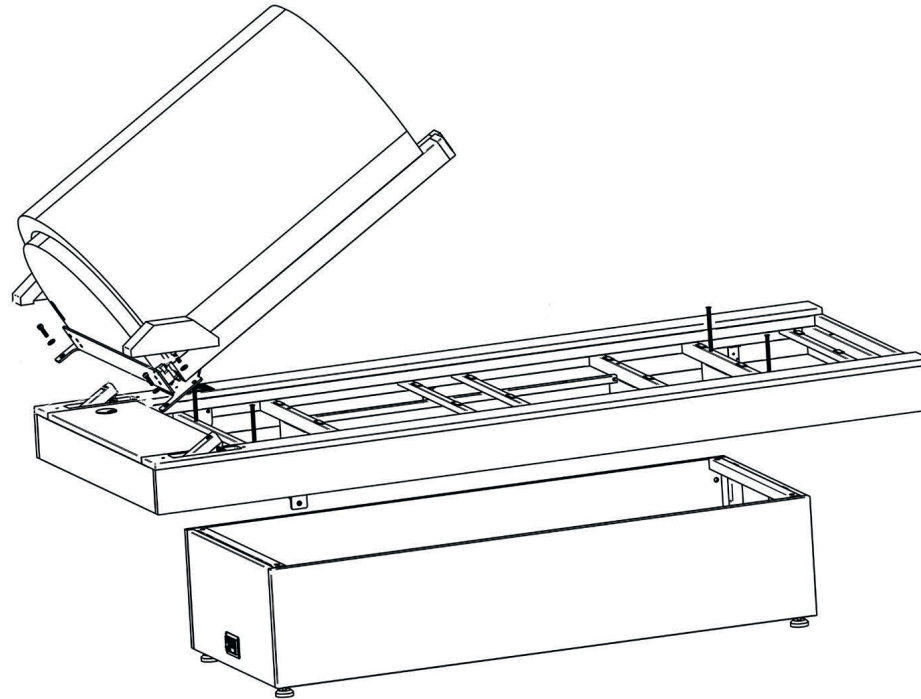

(+ WIFI control mode via tablet)

## SECURITY

**Power supply:** electronic controller and circuit-breaker switch  
**Thermal:** 5 thermal fuses 85°C (1 for each panel)

## ELECTRIC

**Power supply:** 100 - 240 V  
**Power:** 940 W/hour  
(i.e. 470 W per session at maximum intensity)  
**Long infrared:** 5 panels  
(2 upper domes / 3 lower domes)

## PACKAGE

**Base :** 105 cm x 240cm x 71 cm  
**Dôme :** 123 cm x 90 cm x 76 cm

## WEIGHT

**Net weight :** 135 kg (hors options)  
**Gross weight :** 290 kg

# ID RENAISENS TECHNICAL SHEET

CE standard.  
Domes patented in Japan and the United States.  
Catalyst patented by INPI.



JAPANESE TECHNOLOGY  
ITALIAN MANUFACTURE  
FRENCH DESIGN

3-YEAR GUARANTEE

LOW CONSUMPTION

PERSONNALISATION

## DIMENSIONS

**Length:** 225 cm  
**Width :** 90 cm  
**Height (table):** 50 cm  
**Upper dome:** 91 cm x 72 cm x 44 cm  
**Lower dome:** 91 cm x 61 cm x 39 cm

## COMPOSITION

**Outside Domes:** artificial leather  
**Domes interior:** 5 Black Carbon panels  
**Catalyst:** ceramic/titanium - technology  
**Mattress:** 50 mm foam - 30 kg/m<sup>3</sup>  
**Polyurethane cover:** cream  
**Cushion:** white artificial leather  
**Table:** Metal structure + wood panels covering and customisable veneer

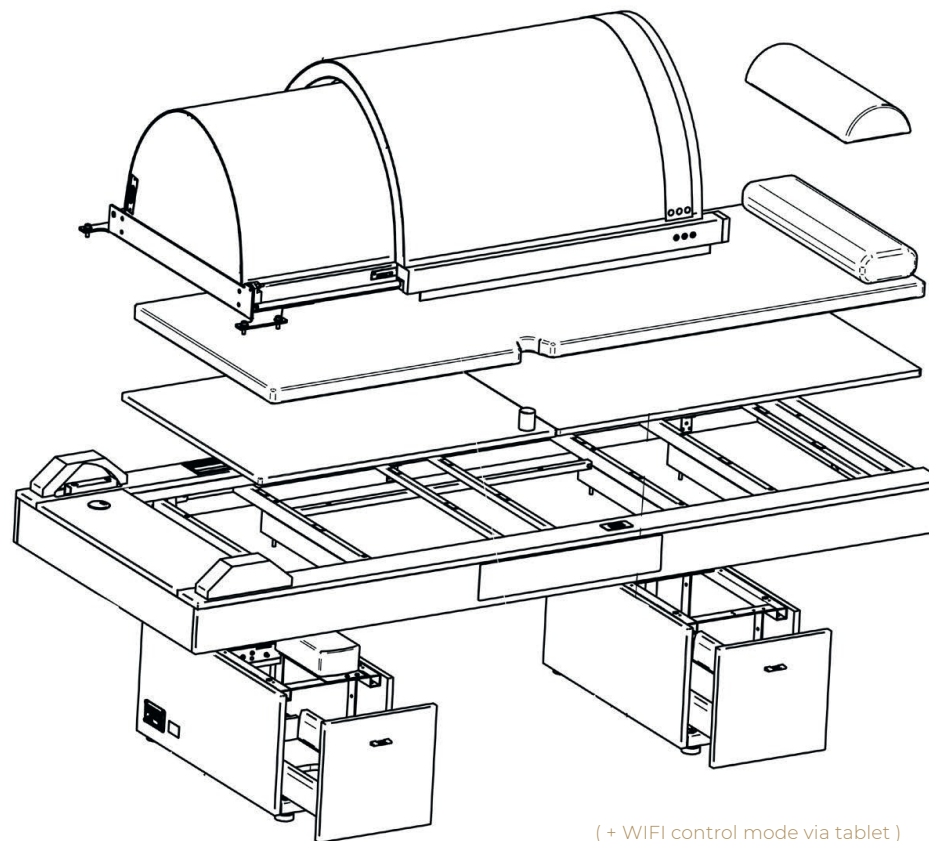

( + WIFI control mode via tablet )

## PACKAGE

**Base :** 105 cm x 240cm x 71 cm  
**Dôme :** 123 cm x 90 cm x 76 cm

## WEIGHT

**Net weight:** 170 kg (hors options)  
**Gross weight :** 290 kg

## SECURITY

**Power supply:** electronic controller and circuit-breaker switch  
**Thermal:** 5 thermal fuses 85°C (1 for each panel)

## ELECTRIC

### LOW CONSUMPTION

**Power supply:** 100 - 240 V  
**Power:** 940 W/hour  
(i.e. 470 W per session at maximum intensity)  
(+ 90 W for ID RenaiSens electric motors) (+ 20 W with ID MOOD option)  
(+ 90 W with the SENS option)  
**Long infrared:** 5 panels  
(2 upper domes / 3 lower domes)

# ID OTEIRE TECHNICAL SHEET

CE standard.  
Domes patented in Japan and the United States.  
Catalyst patented by INPI.

JAPANESE TECHNOLOGY  
ITALIAN MANUFACTURE  
FRENCH DESIGN

3-YEAR GUARANTEE

LOW CONSUMPTION

PERSONNALISATION

## DIMENSIONS

**Length:** 225 cm + 33 cm (headrest)  
**Width :** 90 cm  
**Height (table):** 56 cm  
**Upper dome:** 91 cm x 72 cm x 44 cm  
**Lower dome:** 91 cm x 61 cm x 39 cm

## COMPOSITION

**Outside Domes:** artificial leather  
**Domes interior:** 5 Black Carbon panels  
**Catalyst:** ceramic/titanium - technology  
**Mattress:** 50 mm foam - 30 kg/m<sup>3</sup>  
**Polyurethane cover:** cream  
**Cushion:** white artificial leather  
**Table:** Metal structure + 2 colones + headrest + wood panels covering and customisable veneer

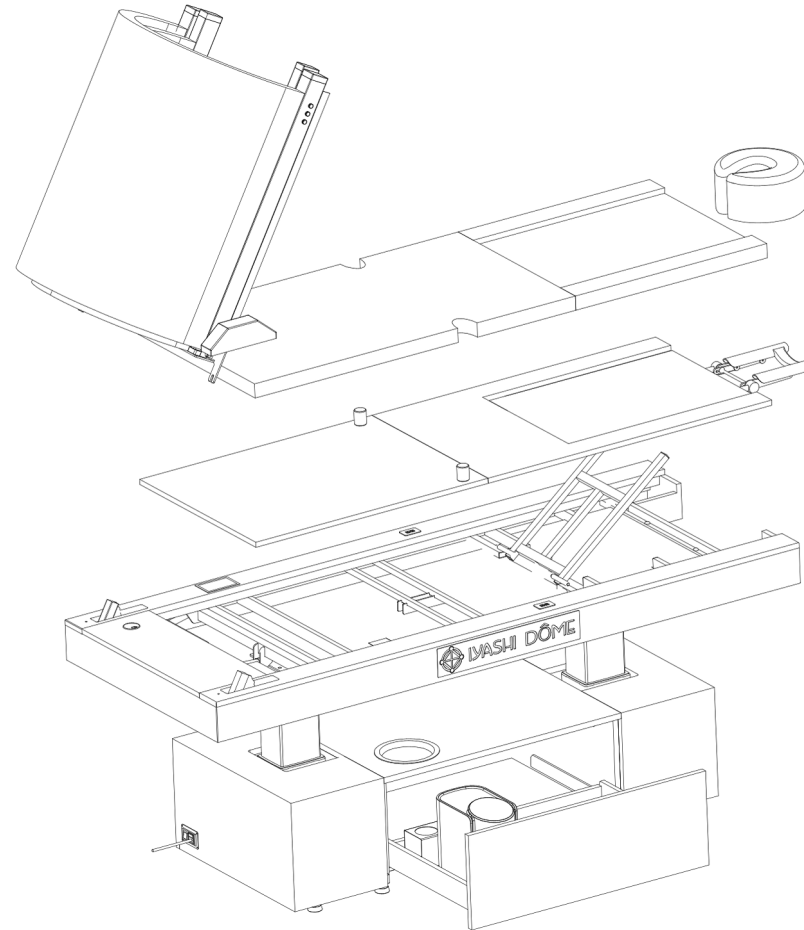

(+ WIFI control mode via tablet)

## PACKAGE

**Base :** 105 cm x 240cm x 71 cm  
**Dôme :** 123 cm x 90 cm x 76 cm

## WEIGHT

**Net weight:** 170 kg (excluding options)  
**Gross weight:** 290 kg

## SECURITY

**Power supply:** electronic controller and circuit-breaker switch  
**Thermal:** 5 thermal fuses 85°C (1 for each panel)

## ELECTRIC

### LOW CONSUMPTION

**Power supply:** 100 - 240 V  
**Power:** 940 W/hour appareil  
(i.e. 470 W per session at maximum intensity)  
(+ 90 W for ID RenaiSens electric motors) (+ 20 W with ID MOOD option)  
(+ 90 W with the SENS option)  
**Long infrared:** 5 panels  
(2 upper domes / 3 lower domes)