

ID FIRST TECHNICAL SHEET

CE standard.
Domes patented in Japan and the United States.
Catalyst patented by INPI.

JAPANESE TECHNOLOGY
ITALIAN MANUFACTURE
FRENCH DESIGN

2-YEARS GUARANTEE

LOW CONSUMPTION

DIMENSIONS

Length: 225 cm
Width: 90 cm
Height (table): 50 cm
Upper dome: 91 cm x 72 cm x 44 cm
Lower dome: 91 cm x 61 cm x 39 cm

COMPOSITION

Outside Domes: artificial leather
Domes interior: 5 Black Carbon panels
Catalyst: ceramic/titanium - technology
Mattress: 50 mm foam - 30 kg/m³
Polyurethane cover: cream
Cushion: white artificial leather
Table: Metal structure + wood panels covering

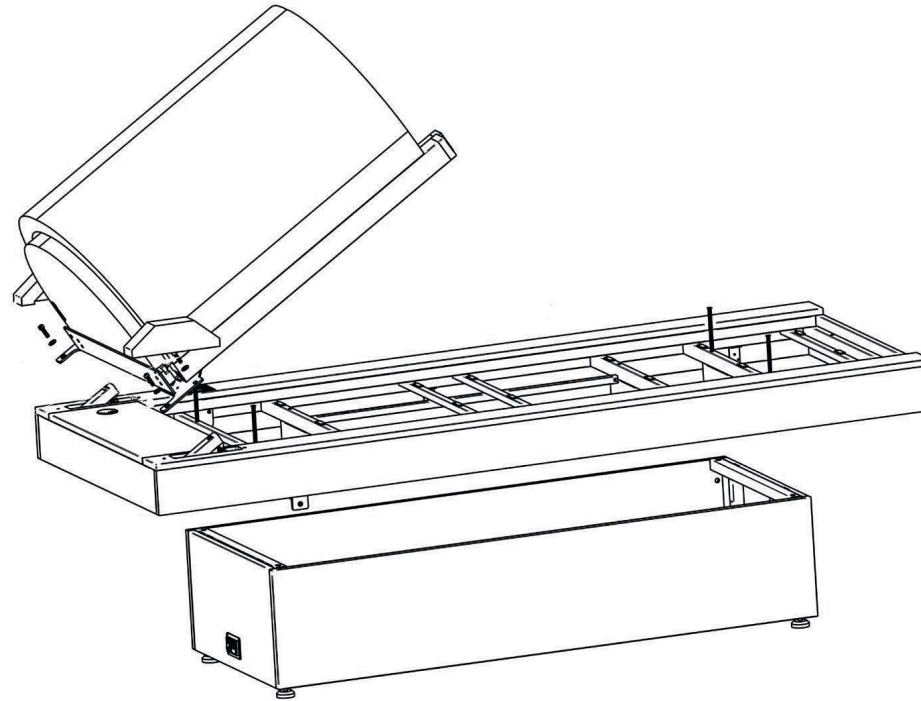

(+ WIFI control mode via tablet)

PACKAGE

Base : 105 cm x 240cm x 71 cm
Dôme : 123 cm x 90 cm x 76 cm

WEIGHT

Net weight : 164 kg (hors options)

SECURITY

Power supply: electronic controller and circuit-breaker switch
Thermal: 5 thermal fuses 85°C (1 for each panel)

ELECTRIC

Power supply: 240 V
Power: 940 W/hour
(i.e. 470 W per session at maximum intensity)
Long infrared: 5 panels
(2 upper domes / 3 lower domes)

ID RENAISSANS TECHNICAL SHEET

CE standard.
Domes patented in Japan and the United States.
Catalyst patented by INPI.

JAPANESE TECHNOLOGY
ITALIAN MANUFACTURE
FRENCH DESIGN

3-YEARS GUARANTEE

LOW CONSUMPTION

CUSTOMIZATION

DIMENSIONS

Length: 225 cm
Width : 90 cm
Height (table): 50 cm
Upper dome: 91 cm x 72 cm x 44 cm
Lower dome: 91 cm x 61 cm x 39 cm

COMPOSITION

Outside Domes: artificial leather
Domes interior: 5 Black Carbon panels
Catalyst: ceramic/titanium - technology
Mattress: 50 mm foam - 30 kg/m³
Polyurethane cover: cream
Cushion: white artificial leather
Table: Metal structure + wood panels covering and customisable veneer

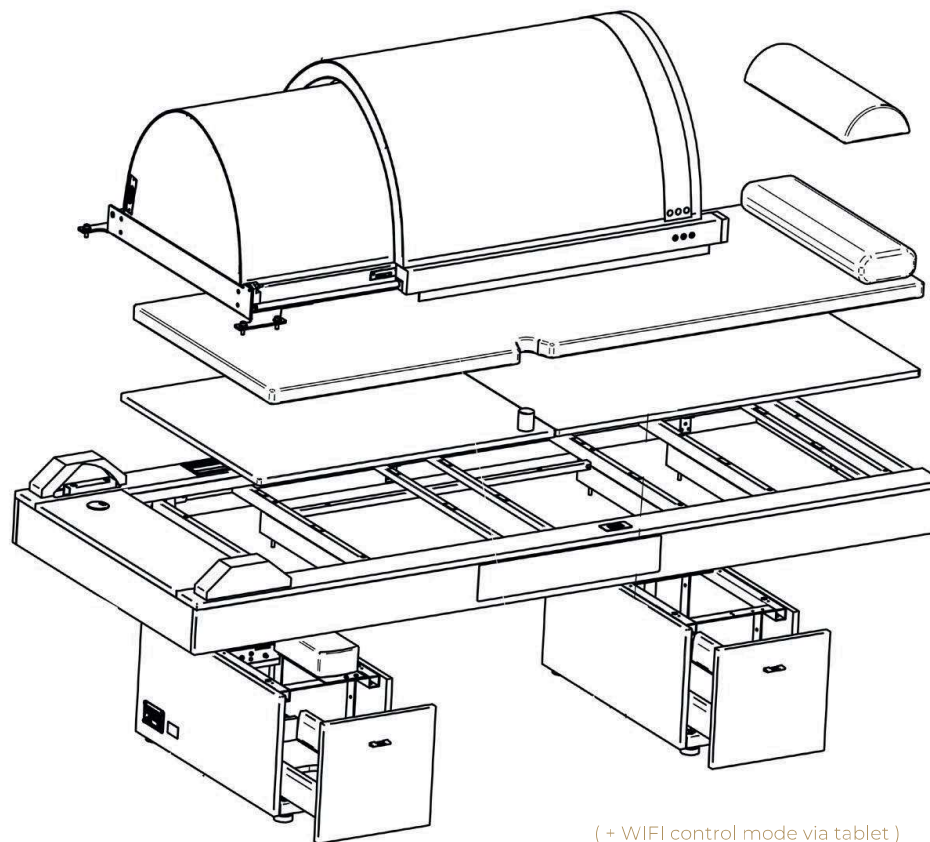

PACKAGE

Base : 105 cm x 240cm x 71 cm
Dôme : 123 cm x 90 cm x 76 cm

WEIGHT

Net weight: 179 kg (hors options)

SECURITY

Power supply: electronic controller and circuit-breaker switch
Thermal: 5 thermal fuses 85°C (1 for each panel)

ELECTRIC

LOW CONSUMPTION

Power supply: 240 V
Power: 940 W/hour
(i.e. 470 W per session at maximum intensity)
(+ 90 W electric motors)
(+ 150 W with the SENS option)
Long infrared: 5 panels
(2 upper domes / 3 lower domes)

ID OTEIRE TECHNICAL SHEET

CE standard.
Domes patented in Japan and the United States.
Catalyst patented by INPI.

JAPANESE TECHNOLOGY
ITALIAN MANUFACTURE
FRENCH DESIGN

3-YEARS GUARANTEE

LOW CONSUMPTION

CUSTOMIZATION

DIMENSIONS

Length: 225 cm + 33 cm (headrest)
Width : 90 cm
Height (table): 56 cm
Upper dome: 91 cm x 72 cm x 44 cm
Lower dome: 91 cm x 61 cm x 39 cm

COMPOSITION

Outside Domes: artificial leather
Domes interior: 5 Black Carbon panels
Catalyst: ceramic/titanium - technology
Mattress: 50 mm foam - 30 kg/m3
Polyurethane cover: cream
Cushion: white artificial leather
Table: Metal structure + 2 colones + headrest + wood panels covering and customisable veneer

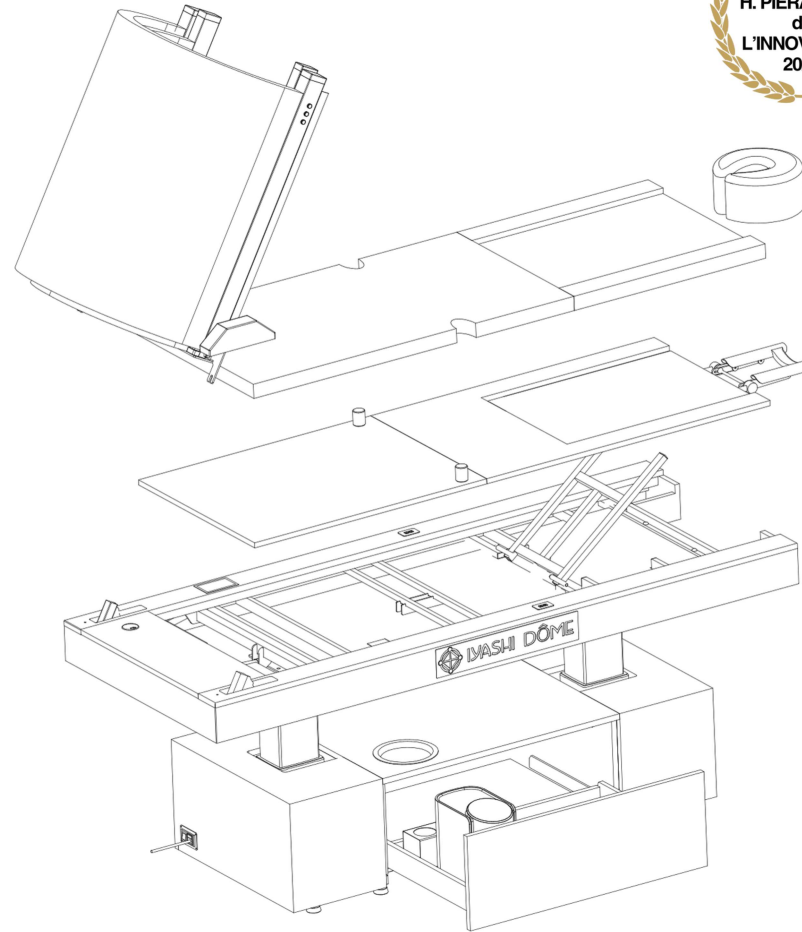

(+ WIFI control mode via tablet)

PACKAGE

Base : 105 cm x 240cm x 71 cm
Dôme : 123 cm x 90 cm x 76 cm

WEIGHT

Net weight: 260 kg (excluding options)

SECURITY

Power supply: electronic controller and circuit-breaker switch
Thermal: 5 thermal fuses 85°C (1 for each panel)

ELECTRIC

LOW CONSUMPTION

Power supply: 240 V
Power: 940 W/hour appareil
(i.e. 470 W per session at maximum intensity)
(+ 90 W electric motors)
(+ 1200 W top and backrest)
(+ 150 W with the SENS option)
Long infrared: 5 panels
(2 upper domes / 3 lower domes)